



Product Presentation 2024

Pyrolysis Technologies of the Future

Completely environmentally friendly
solution for waste utilization.

PYR^{OLY}



5 tonnes of waste

is produced by the average European each year.

Only 38%

of waste in the EU is recycled

Over 60%

of household waste still goes to landfill in some EU countries

Increasing Stringency in Regulatory Framework



Landfill Prohibition: End-of-life tires and shredded tires are not allowed to be disposed of in landfills.



Incineration Ban: Burning rubber products and the outdoor use of shredded tire granules are strictly prohibited.



Extended Producer Responsibility (EPR): Corporate focus shifts towards recycling as a vital concern.



EU Waste Directive: Challenges in the Utilization of Recovered Materials



Rising CO2 Costs: The expense associated with burning tires is steadily increasing due to the escalating costs of carbon dioxide emissions.



Approximately 3.3 million tons of used tires are discarded each year in Europe.

Currently, approximately 4 billion tires are residing in landfills worldwide. According to certain estimates, up to 41% of tires that have reached the end of their life cycle may find themselves in various landfills, stockpiles, or face an uncertain fate.

~56% is incinerated or landfilled



What is Agricultural Waste?

Fundamentally, agricultural waste encompasses the residual by-products discarded from diverse agricultural activities. This includes a broad range of materials such as crop residues (unused parts remaining after harvesting), livestock manure, remnants of harvested market produce, packaging, pesticides, and other chemical fertilizers used in farming.





700 million tons

of agricultural waste is produced annually by the EU

Sludges Generated by Oil Industry and Waste Treatment Plants

The oil industry challenge is oil sludge treatment, which is formed as a result of almost any operation involving the handling of oil products and oil

Solids and residues accumulate as sludge in various water treatment processes. The sludge generated at different stages of water/wastewater treatment facilities needs to undergo proper dewatering and disposal procedures.

Petroleum sludge, a solid emulsified waste and contaminant prevalent in the petroleum industry, is on the rise due to increased business growth in the oil sector. The escalating volumes of oily sludge, marked by high viscosity and toxicity, underscore the imperative need for thorough sludge treatment before disposal.



Municipal Solid Waste (MSW) Problem

The EU faces substantial waste generation across various sectors, including manufacturing, food, construction, electronics, textiles, and more. Annually, the EU produces a staggering 2.2 billion tonnes of waste, with municipal waste accounting for over a quarter (27%) of this total.

225.7 million tones

of municipal waste was produced in EU 2020

49 %

of municipal waste is recycled





All that waste can be converted into
valuable products!

Our Solution

A **pyrolysis plant** that can efficiently convert all kinds of different waste including industrial, municipal and bio waste into a range of fuel products and energy.

- The plant is fully continuous and operates **24/7**, running 340 days a year without interruption.

PYROLY[®]
www.pyroly.com

All achieved in an environmentally friendly manner.
With zero CO2 footprint.

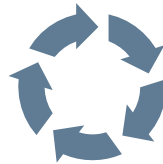

Convert waste into valuable products with PYROLY!



Highly profitable business with eco-friendly global impact.

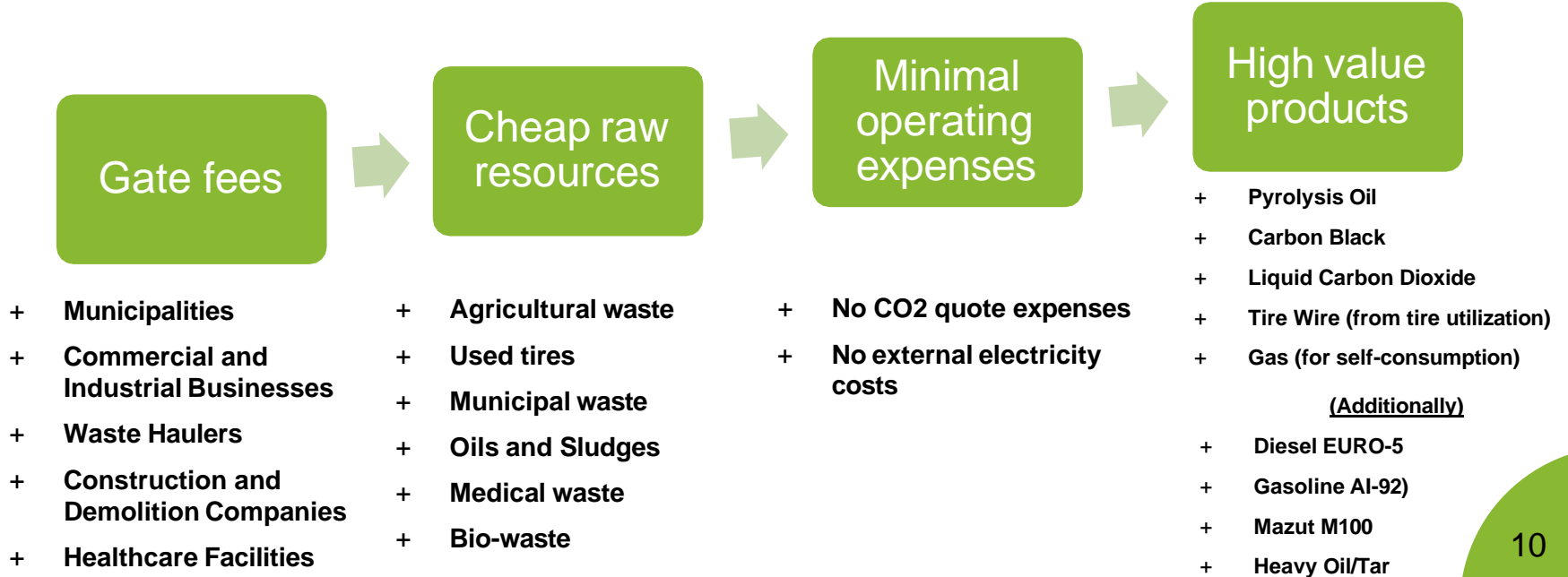

End-Product Percentage Yields

Pyrolysis Oil ~57%

Carbon Black ~25%

Liquid CO2 ~10%

Technical water ~3%

Tire Wire* ~5%

1. After the first stage, the processing of waste with a moisture content of up to 20% in the thermo-pyrolysis reactor "PYROLY" yields the following results:

The complex generates heat and electrical energy as by-products. Most of the electrical energy is used internally, and the heat can be applied in greenhouses or supplied to city heating networks through agreements with local authorities.

*When mainly processing used tires.

Gasoline AI-92: 25 – 30% Density at 20°C, g/cm³ = 0.71-0.76.

Diesel Euro-5: 45 – 50% Density at 20°C, g/cm³ = 0.80-0.85.

Mazut M100: 12 – 15% Density at 20°C, g/cm³ = 0.92-0.99.

Heavy tar: 5 – 8% Density at 20°C, g/cm³ = 1.2-1.5.

Syngas: 15 – 20% (50% used in production).

2. After the second stage, which involves the fractionation of pyrolysis liquid in a specialized refinery, the following results are obtained:

Potential End-Product Usage

	Pyrolysis Oil	Liquid CO2	Carbon Black	Gasoline Ai-92	Diesel Euro-5	Mazut M100	Heavy Oil/Tar
Product usage	<ul style="list-style-type: none"> • Combustion in boilers. • Marine fuel (limited). 	<ul style="list-style-type: none"> • Food Production: carbonated beverages. • Dry ice. 	<ul style="list-style-type: none"> • Fuel briquettes for boilers. 	<ul style="list-style-type: none"> • Fuel for automotive transportation. 	<ul style="list-style-type: none"> • Fuel for automotive and specialized vehicles. 	<ul style="list-style-type: none"> • Marine fuel. 	<ul style="list-style-type: none"> • Construction material.
Additional market opportunities	<ul style="list-style-type: none"> • Oil refinery • Fuel for low-speed diesels. 	<ul style="list-style-type: none"> • Cylinder refilling for: Welding operations, fire extinguishers and gas fire suppression systems. • Slaughterhouses. 	<ul style="list-style-type: none"> • Sorbent Production. • Construction Material. • Gas Filter Manufacturing. • Tire rubber production. 	<ul style="list-style-type: none"> • Production of high-octane additives for automotive vehicles. • Paint and coating manufacturing. 	<ul style="list-style-type: none"> • Boiler fuel. 	<ul style="list-style-type: none"> • Boiler fuel. • Fuel for low-speed diesels. 	<ul style="list-style-type: none"> • Asphalt production. • Paint and coating manufacturing.
Potential clients	<ul style="list-style-type: none"> • River maritime companies. • Farms. • Municipal boiler houses. • Oil refiners. 	<ul style="list-style-type: none"> • Local catering establishments. • Local CO2 cylinder refilling services. • Food manufacturing companies. • Science and pharmaceutical companies. 	<ul style="list-style-type: none"> • Farms. • Local small Boiler houses. • Manufacturers of construction Materials and filters. • Tire manufacturing companies. 	<ul style="list-style-type: none"> • Gas stations. • Oil traders. • Urban vehicle fleets. 	<ul style="list-style-type: none"> • Gas stations . • Oil traders. • Urban vehicle fleets. • Local boiler houses. 	<ul style="list-style-type: none"> • River maritime companies. • Farms. • Local boiler houses. 	<ul style="list-style-type: none"> • Local asphalt plants. • Local manufacturers of waterproofing coatings.

Competitive Advantage



	Other companies like Carbofex, Green Fuel Nordic, Beston, Treotech etc.	Our technologies
Has solutions for industrial scale		
Has no exhaust/chimney		
Energy self-sufficient		
Emits no CO2		
Short payback period		
Offers mobile capabilities		
Can be used as a power station		

Our solutions achieve low operating expenses thanks to efficient utilization process, zero CO2 emissions, and full energy self-sufficiency.

About Our Pyrolysis Plants

For diverse purposes, PYROLY offers 3 main types of pyrolysis plants. All the plants can be configured and modified to achieve maximum efficiency and the desired end-product output volume.

1. **PYROLY-EKOPYR OS:** Treats waste oils, sludges and acidic bitumen.
2. **PYROLY-EKOPYR RP:** Processes rubber, plastics, and polyethylene.
3. **PYROLY-EKOPYR EG:** Handles all types of waste mixtures.

Key technological advantages:

- The system can utilize excess heat generated during waste utilization, promoting energy efficiency.
- The technology is versatile and can be deployed as mobile units, even on large ships.
- Waste-to-fuel processing plants can operate as power stations.
- The system's reactor can handle various materials, from household waste, oil extraction residues, tires, and more.
- The system boasts unique environmental compatibility with zero harmful emissions.
- The technology showcases high energy efficiency.
- There's no need for fine raw material grinding.
- Have solutions for utilizing more than 50,000 tons of waste per year.

Ensuring Environmental Performance in Waste Processing

To ensure production ecology, the complex employed three filtering systems and linking of harmful substances:

1. A three-tiered system for flue gas from the heater, including a mechanical stage with a dry cyclone and a scrubber for further cleaning, a liquid stage with a wet scrubber to remove acidic fragments, and a third stage with a dry filter-sink for additional purification.
2. Two-step purification of pyrolytic gas before release to the gas turbine power station and pyrolysis reactor, involving bulk absorbers for maximum cleaning and reducing harmful emissions.
3. Two-stage pyrolysis cleaning fluid using heated pyrolysis liquid circulated through bulk absorbers, ensuring a purification and filtration system that eliminates the possibility of gas and liquid emissions into the environment.

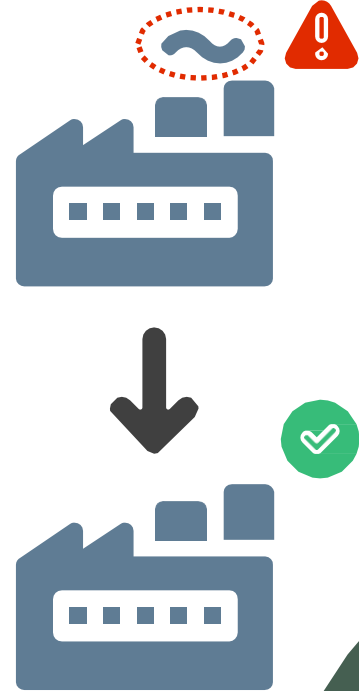

Overview of the complex

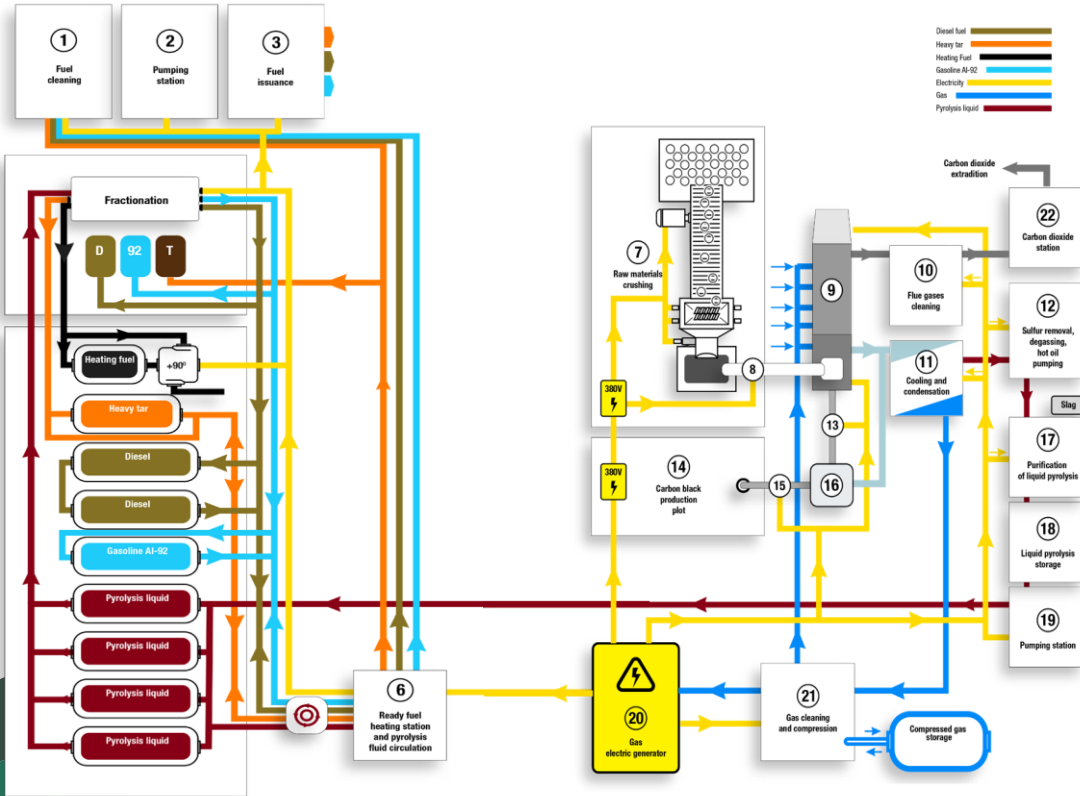

Part of the proposed complex includes:

- Waste screening: selection of glass, metal, stone, concrete, and radioactivity checking of materials.
- Grinding of materials into specific factions.
- Mechanisms for the movement of raw materials.
- Pyrolysis processing plot for raw materials.
- Transitional tanks for pyrolysis oil.
- Filtration through tubing.
- Carbon black warehouse.
- Processing of materials not subject to pyrolysis.
- Power plant.
- Separation of pyrolysis liquid into fractions.
- Transitional tanks for finished products.
- Issuance plot for the finished product.

Pricing



	EKOPYR-50	EKOPYR-100	EKOPYR-200	EKOPYR-800	EKOPYR-MAX
Waste Processing Capacity	50m3 / day	100m3 / day	200m3 / day	800m3 / day	>1000m3 / day (custom capacity)
Annual Capacity (Metric)*	~8,500 t	~20,400 t	~42,500 t	~170,000 t	>170,000 t (custom capacity)
Price**	After RFQ	After RFQ	After RFQ	After RFQ	Custom
Investment return	~4 years	~3.5 years	~3 years	~2.5 years	-
Ann. Pyrolysis Oil	~4,788 t	~11,628	~24,225	~96,900	-
Ann. Carbon Black	~2,100 t	~5,100	~10,625	~42,500	-
Ann. Liquid CO2	~850 t	~2,040	~4,250	~17,000	-

Additionally, indicative annual outputs from our pyrolysis oil refinery

Diesel Euro-5	~2,400 t	~5,800 t	~12,100 t	~48,500 t	-
Gasoline AI-92	~1,450 t	~3,500 t	~7,200 t	~29,100 t	-
Fuel Oil M100	~720 t	~1,700 t	~3,600 t	~14,500 t	-
Heavy Oil/Tar	~380 t	~930 t	~1,900 t	~7,750 t	-

* The annual capacity in metric tons varies based on the waste type used. **Pricing can vary a lot depending on the configuration. Contact for RFQ.

Interested?

Don't hesitate to reach out to us for a free RFQ! We provide tailored solutions based on our client's goals and needs. PYROLY solutions can be configured for specific purposes to achieve maximum utilization efficiency.

Additionally, our company offers free consulting on business opportunities using our pyrolysis waste-to-fuel plants, especially beneficial for clients new to the industry.

If you have any further questions, feel free to contact us at:

www.scitechno.ru

info@scitechno.ru



PYROLY[®]
www.pyroly.com

